



**On Stage
with
the Best**

TradeTools™

Short Stop

MOMENTARY MICROPHONE MUTING SWITCH

APPLICATION INFORMATION

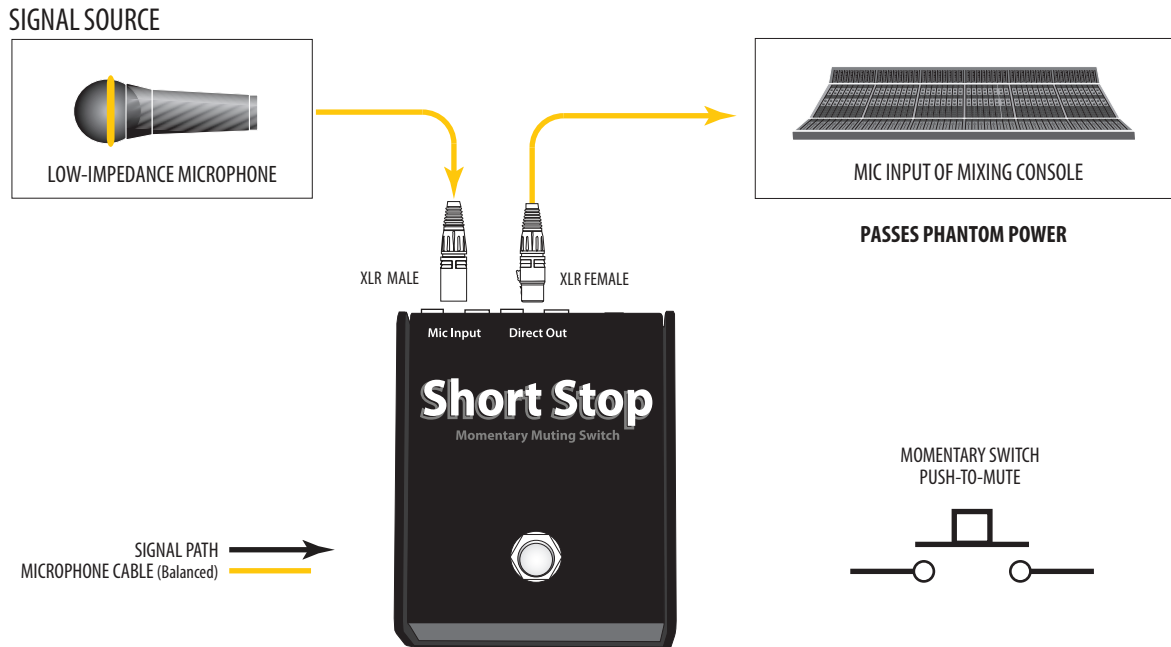

CONTROLS:

- MIC INPUT:** Female 3-pin XLR-type connector accepts input from any balanced or floating low impedance (150 ohm nominal) microphone or similar signal source.
- DIRECT OUT:** Male 3-pin XLR-type connector provides output to sound system input.
- ACTIVATION SWITCH:** Momentary, SPST (single pole, single throw) switch shorts pin 2 and pin 3 of the XLR connectors together to produce the muting effect.

NOTES:

- 1. For safety reasons, all equipment with 3-wire AC line cords should be connected to properly grounded receptacles.**
- Microphones require a ground connection somewhere in the signal path. For this reason it is suggested that a properly grounded mixer always be connected to the DIRECT OUTPUT.
- Direct boxes receiving inputs from AC-line-powered sources such as keyboards or stage amplification should have their GND/LIFT switches set to LIFT and the source equipment line cords properly connected to grounded 3-wire receptacles whenever possible. (See note 1).

CIRCUIT DIAGRAM:

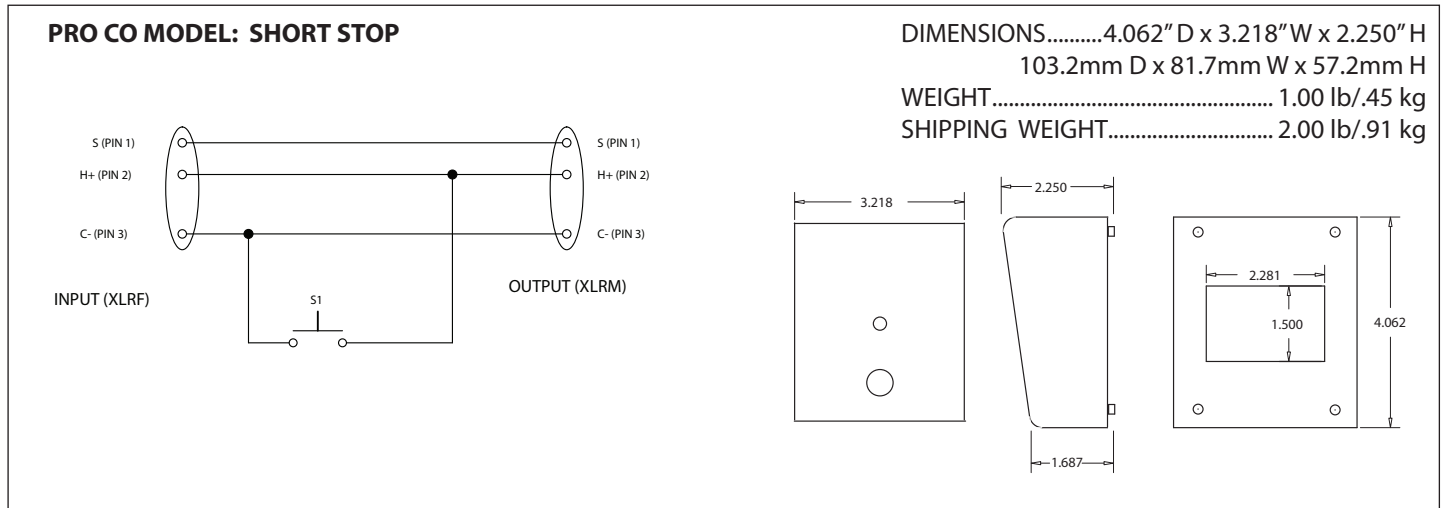

Other TradeTools™ Products from Pro Co

- AV1B Audio/Video Interface Unit
- AVP1 Wallplate Format Audio/Video Interface Unit
- AVP1V Wallplate Format Audio/Video Interface Unit with Input Level Control
- CB1 Direct Box
- DB1 Professional Direct Box
- DB2 Professional Stereo Direct Box
- DB4A Rackmount Quad Direct Box
- DBA1 Professional Active Direct Box
- HJ4P Professional Stereo headphone Junction Box
- HJ6 Headphone Junction Box
- iFace Portable Audio Player Interface
- iGate Universal Audio Gateway
- iPlate Wallplate Format Portable Audio Player Interface
- iRack Rackmount Portable Audio Player Interface
- IT1 Isolation Transformer Unit
- IT4A Rackmount Quad Isolation Transformer Unit
- IT8A Rackmount 8-ch. Isolation Transformer Unit
- LS82 Rackmount 8-ch. 1:2 Line Level Splitter

- MC2 Microphone Combiner
 - MS2 1:2 Microphone Splitter
 - MS3 1:3 Microphone Splitter
 - MS42A Rackmount Quad 1:2 Microphone Splitter
 - MS43A Rackmount Quad 1:3 Microphone Splitter
 - MS82 Rackmount 8-ch. 1:2 Microphone Splitter
 - MS82P Rackmount 8-ch. 1:2 Phantom Power Microphone Splitter
 - MS83 Rackmount 8-ch. 1:3 Microphone Splitter
 - MS83P Rackmount 8-ch. 1:3 Phantom Power Microphone Splitter
 - Panic Button Multi-mode Mic A/B & Muting Unit
 - Power Mute Multi-Mode Mic Muting Switch
 - Short Stop Momentary Press-to-Mute Mic Switch
 - Sign Off Latching Mic Muting Switch
 - SAS1 Sports Announcer's Switch (Press-to-Talk)
 - SAS2 Sports Announcer's Switch (Press-to-Talk) with Gooseneck
 - SAS3 Sports Announcer's Switch (Press-to-Talk) with wired Gooseneck
 - Switch Witch Rackmount 4-ch. Powered Monitor Selector
- ... plus our full line of audio cabling, snakes!**



Pro Co Sound
 225 Parsons Street | Kalamazoo, MI 49007
 800-253-7360

» www.procosound.com